

FSA-D

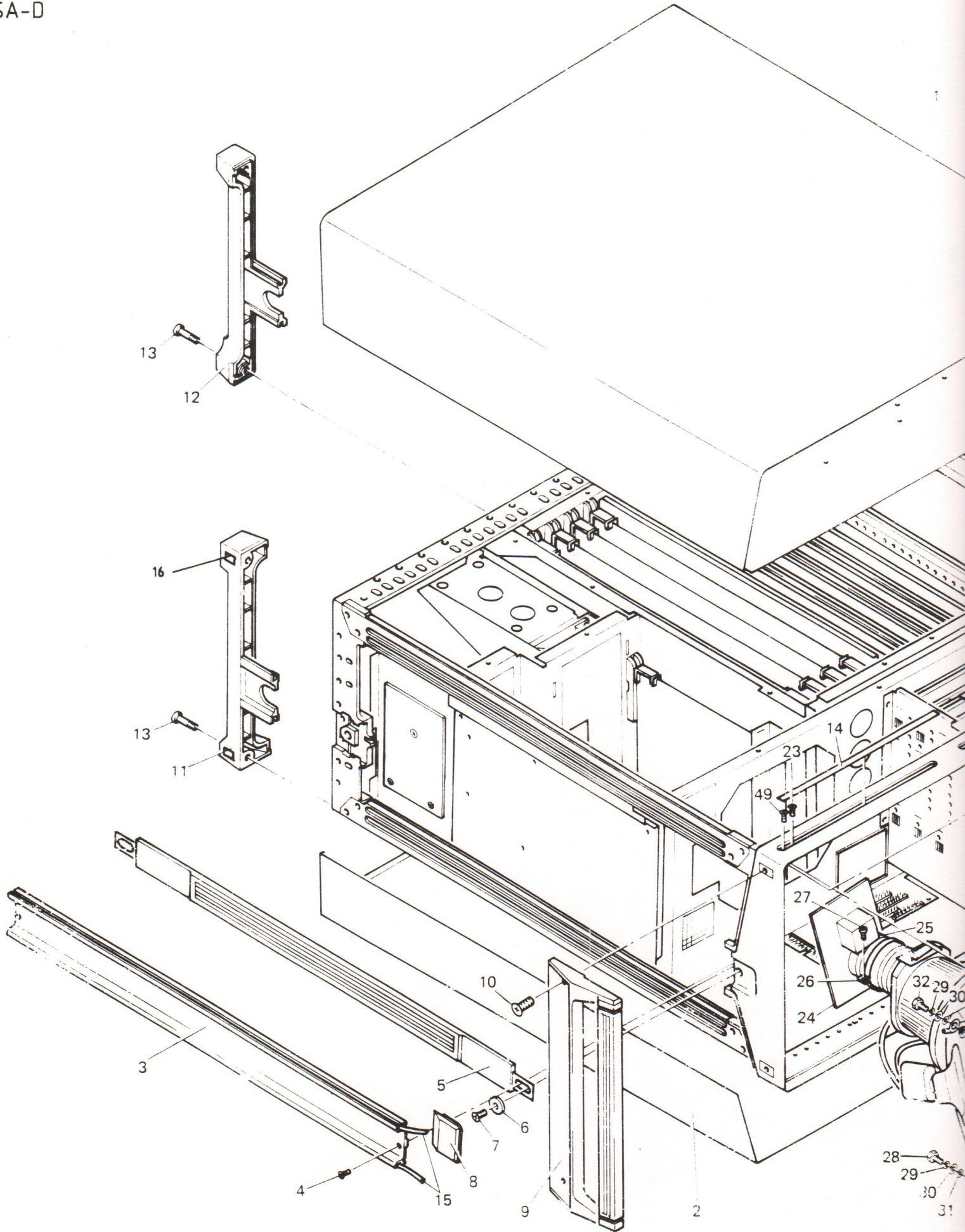

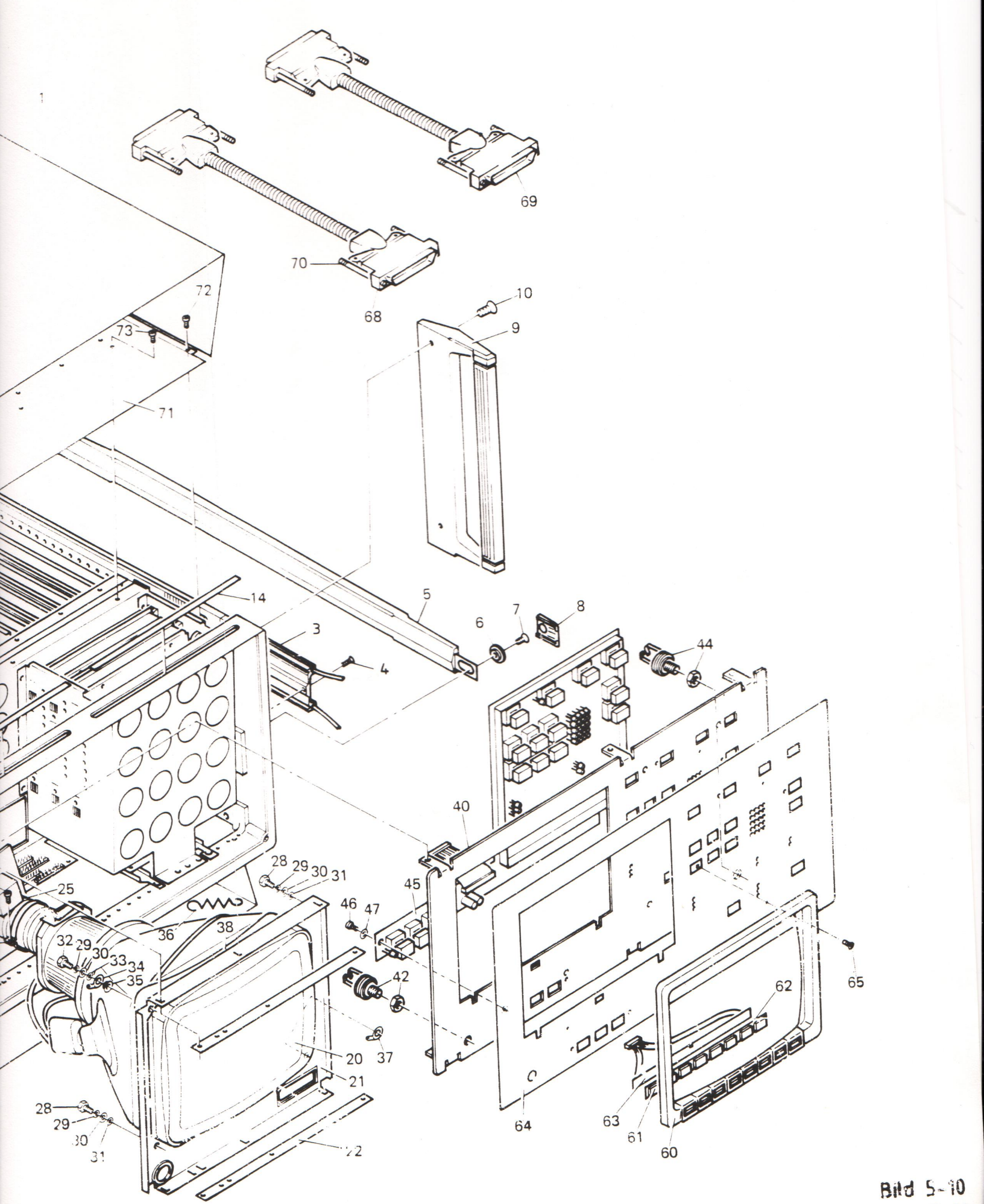

Liste zu den Bildern 5-10 ... 5-12 (Anzeige-Teil)

List for Figs. 5-10 to 5-12 (Display unit)

Lfd. Nr.	Kennzeichen	Menge	Benennung/Beschreibung	Sachnummer
No.	Unit/Comp.No.	Qty.	Designation	Stock No.
1		1	MZ Haube, oben 5E 1/1 T570 Cover, top	806.1229
2		1	MZ Haube, unten 5E 1/1 T570 Cover, bottom	806.1235
3		2	MF Seitenleiste T570 Side strip	396.3096
4		4	VS M3x6 DIN 965 A4	081.9378
5		2	ZM Tragegriff T570 Carrying handle	396.3238
6		4	MR Griffbuchse Washer	396.3321
7		4	VS M 4x10 DIN 965 A4	081.9478
8		4	MF Abdeckung, Griffseite Cover, handle side	396.3338
9		2	KS Frontgriff 5E Front handle	396.5318
10		4	VS M 4x8 DIN 965 A4	396.1087
11			ZM Rückwandfuß, links 5E Rear-panel foot, left	396.4405
12			ZM Rückwandfuß, rechts 5E Rear-panel foot, right	396.4192
13			VS Ansatzschraube M4 K.D 7985 Screw	396.4492
14		2	MF Stapelnutabdeckung Cover for groove	396.4711
15		6M	WG HF Dichtungsschnur RF shielding cord	396.1035
16		4	WT Seitenfuß Side foot	396.4692
20	V530	1	ZM Colour Display Tube	805.8007
21		1	MZ Halterung Screen support	806.2119

Lfd. Nr.	Kennzeichen	Menge	Benennung/Beschreibung	Sachnummer
No.	Unit/Comp.No.	Qty.	Designation	Stock No.
22		2	MZ Platte Plate	806.2131
23		6	VS M3x8 DIN 965 A4	081.9384
24	A53	1	EE Socket Board	805.7017.02
25		1	MZ Halterung Support	805.7169
26		1	ZM Schelle Clamp	805.7181
27		1	VS M 3x12 DIN 7985 A4	081.9090
28		2	VS M 4x6 DIN 933	032.0935
29		4	VS 4 DIN 137 A2	005.0315
30		4	VS 4,3 DIN 9021 A4	031.5191
31		2	VS 4,3 DIN 433 A4	082.4586
32		2	VS M 4x10 DIN 933	032.0958
33		2	MB Scheibe Washer	806.2160
34	W533	1	DX Massekabel W533 Ground cable	805.7123
35		2	MB Tülle Sleeve	806.2154
36		1	OF Zugfeder 6,4 x 0,6 x 29,8 Spring	247.4304
37		1	VL Lötöse 1-fahrig f. M8 Soldering tag, single for M8	034.9946
38	L531	1	LD Entmagnetisierspule Demagnetization coil	805.7117
40		1	MZ Montageplatte Mounting plate	804.9939
42	X2	1	FT Klinkeneinbaubuchse 3P Jack socket	516.8175
44	X1	1	FT Klinken-Schalbuchse Jack socket	252.5834
45	A111	1	ED Keyboard Display	805.6310

Lfd. Nr.	Kennzeichen	Menge	Benennung/Beschreibung	Sachnummer
No.	Unit/Comp.No.	Qty.	Designation	Stock No.
46		7	VS M 3x6 DIN 7985 A4	081.9061
47		7	VS 3 DIN 137 A2	005.0296
49		6	VS M 3x8 DIN 965 A4	081.9384
60		1	MP Bildschirmrahmen Screen frame	396.6266
61		8	MP Tastenkappe Key cap	396.6314
62		1	SB Kontaktmatte Contact panel	396.6272
63		1	ZE Kontaktplatte Contact plate	396.6289
64		1	KB Frontplatte (englisch) Front panel (English)	804.9951
65		3	VS Senkschraube M 1,6x3 lichtgrau Countersunk screw M1.6 x 6, light grey	396.1070
68	W1	1	DX Verbindungskabel W1 Cable	808.6657
69	W2	1	DX Verbindungskabel W2 Cable	808.6670
70		8	MB Schraube Screw	808.6786
71		1	ZM Deckel Cover	804.9600
72		8	VS M 3x6 DIN 965	081.9378
73		14	VS M 3x6 DIN 7985	081.9061
80	A31	1	EE IF-Filter 1 IF filter 1	805.5337.02
81	A32	1	EE IF-Filter 2 IF filter 2	805.4318.02
82	A34	1	EE Lin/Log	805.2315.02
83	A33	1	EE Step Gain	805.3311.02
84	A45	1	EE I/O Board	805.0812.02

Lfd. Nr.	Kennzeichen	Menge	Benennung/Beschreibung	Sachnummer
No.	Unit/Comp.No.	Qty.	Designation	Stock No.
87	A37	1	EE A/D Converter	805.1319.02
89	A41	1	EE Main Processor	810.2010.02
91	A43	1	EE Graphics	805.0712.02
95	W154	1	DX HF-Kabel W154 RF cable	806.1541
96	W175	1	DX HF-Kabel W175 RF cable	806.1812
97	W151	1	DX HF-Kabel W151 RF cable	806.1529
98	W150	1	DX HF-Kabel W150 RF cable	806.1512
99	W146	1	DX HF-Kabel W146 RF cable	806.1629
103	W153	1	DX HF-Kabel W153 RF cable	806.1535
107	W157	1	DX HF-Kabel W157 RF cable	806.1570
110	W156	1	DX HF-Kabel W156 RF cable	806.1564
111	W155	1	DX HF-Kabel W155 RF cable	806.1558
120		1	MZ Kabelkanal Cable duct	804.9574
121		1	VS M 3x6 DIN 7985 A4	081.9061
129		1	ZM Winkel Bracket	804.9722
130		5	VS M 3x8 DIN 965 A4	081.9384
131		1	MZ Platte Plate	805.9549

Lfd. Nr.	Kennzeichen	Menge	Benennung/Beschreibung	Sachnummer
No.	Unit/Comp.No.	Qty.	Designation	Stock No.
132	E2	1	EV Lüfter Blower	531.7130
133		1	EV Lüftergitter Blower grid	852.0596
134		4	VS M 3x6 DIN 7985 A4	081.9061
135		4	VS 3 DIN 137 A2	005.0296
136		4	VS 3,2 DIN 125 A4	082.4670
137		2	MP Verschlußstopfen Stopper	528.8500
138	X4 bis/to X11	8	FJ Einbaubuchse syst. BNC BNC socket	099.9186
139		9	VL Lötöse 18x10 Solder tag	035.0813
142	X3	1	FT Klinkeneinbaubuchse 3 P Jack socket	516.8175
144	W140	1	DX Kabel W140 Cable	806.1787
145	W136	1	DX Kabel W136 Cable	806.1741
147	W137	1	DX Kabel W137 Cable	806.1758
148	W133	1	DX Kabel W133 Cable	806.1712
149	X132	1	DX Buchseneinheit X132 Socket assembly	806.1612
150	W145	1	DX HF-Kabel W145 RF cable	806.1664
151	W147	1	DX HF-Kabel W147 RF cable	806.1658
152	W135	1	DX Kabel W135 Cable	806.1735
153	W134	1	DX Kabel W134 Cable	806.1729
154		2	VS M 2,5x10 DIN 7985	088.0053
155		2	VS 2,7 DIN 125	082.4663
156		2	VS 2,6 DIN 137	005.0280
157		2	VS M 2,5 DIN 934	088.0230

Lfd. Nr.	Kennzeichen	Menge	Benennung/Beschreibung	Sachnummer
No.	Unit/Comp.No.	Qty.	Designation	Stock No.
160		10	FM Verriegelungsbolzen M. M3 Bolt	099.7783
169		2	VS DIN 965 - M 3 x 6 - A4	081.9378
170		1	MZ Trafo-Halterung Transformer support	805.8288
171		1	MZ Platte Plate	805.8259
172		1	VS M 6x16 DIN 965	071.3454
173	T1	1	ZE Transformator Transformer	805.8236
174		4	VS M 3x10 DIN 7985	081.9084
176		1	VS M 4x8 DIN 7985	081.9178
177		1	VS 4,3 DIN 125	082.4686
178		1	VS 4,3 DIN 6797	016.2837
179		1	FV Flachstecker Gr. 6,3 Terminal	543.6705
181		1	VS M 4 DIN 934	016.4400
184	S1	1	SK Wippschalter 2pol. Rocker switch, 2-pole	553.2925
186	X1	1	FN Netzfilter mit Spannungswähler AC filter with voltage selector	099.3313
187		2	VS M 3x10 DIN 965	081.9390
190		1	MZ Abdeckung Cover	805.8036
191		5	KZ Käfig Insert	085.1936
192		5	VS M 3x6 DIN 7985	081.9061
193		5	VS 3 DIN 137	005.0296
195	E1	1	ZE Lüfter Blower	808.4177
196		4	VS M 3x6 DIN 7985	081.9061
198		4	VS 3 DIN 137	005.0296
199		1	MZ Befestigungswinkel Mounting bracket	805.8071

Lfd. Nr.	Kennzeichen	Menge	Benennung/Beschreibung	Sachnummer
No.	Unit/Comp.No.	Qty.	Designation	Stock No.
200	A22	1	ED Power Supply D-A22	805.8813.02
201		1	MZ Koppelplatte Coupling plate	805.8094
202		4	VS M 3x6 DIN 7985	081.9061
204		2	VS 3,2 DIN 6797	016.2820
205		4	VS M 3x6 DIN 7985	081.9061
206		2	VS 3,2 DIN 125	082.4670
208		1	ZM Befestigungswinkel 1 Mounting bracket 1	808.4077
209	A21	1	ED Power Supply D-A21	808.8513.02
210		9	VS M 3x6 DIN 7985	081.9061
211		5	VS 3 DIN 137	005.0296
212		4	VS 3,2 DIN 125	082.4670
215		1	ZM Platte Plate	805.8265
216		5	VS M 3x6 DIN 7985	081.9061
217		5	VS 3,2 DIN 125	082.4670
218		4	VS M 3x8 DIN 7985	081.9078
219		4	VS 3,2 DIN 125	082.4670
220		1	ZM Z-Winkel Z bracket	805.8065
221		2	ZM Geräteverbinder U-link	806.1370
225		2	ZM Klotz Block	806.1358
226		6	VS M 3x10 DIN 7985	081.9084
250		4	MG Rahmenschiene T570 Frame rail	396.2383
251		16	VS M 3x8 DIN 965	081.9384
252		1	ZM Frontrahmen 5E 1/1 Front frame	396.2154
253		1	ZM Rückrahmen 5E 1/1 Rear frame	396.2290
260		2	MZ Platte Plate	396.9388

Lfd. Nr.	Kennzeichen	Menge	Benennung/Beschreibung	Sachnummer
No.	Unit/Comp.No.	Qty.	Designation	Stock No.
261		2	MZ Leiste Strip	396.9394
262		4	VS M 3x16 DIN 965	081.9410
265		1	ZM Querwand 1 Transverse panel 1	804.9774
266	B1	1	EL Lautsprecher 0,5 W 150 Ohm Loudspeaker	243.1298
267		1	ZM Platte Plate	804.9616
268	W170	1	DX Kabel W170 Cable	806.1670
269		2	VS M 3x8 DIN 965	081.9384
270		1	ZM Winkel Bracket	804.9851
271		4	VS M 3x6 DIN 7985	081.9061
272		6	WT Führungsleiste f. DS 3E Gr. Guide rail	396.7356
273		3	VS M 3x8 DIN 965	081.9384
276	A36	1	EE AF-Unit	809.8518.02
277	A35	1	EE IF Counter	806.0016.02
280		1	ZM Wand vorne Front panel	804.9716
281		1	ZM Längswand 2 Side panel 2	804.9797
282		1	ZM Wand, hinten Rear panel	804.9751
283		2	VS M 3x6 DIN 7985	081.9061
284		10	VS M 3x10 DIN 7985	081.9084
285		10	VS M 3x10 DIN 965	081.9390
286		2	MZ Schiene Rail	804.9700
287		6	VS M 3x6 DIN 7985	081.9061
290		1	ZM Längswand 1 Side panel 1	804.9739
291		1	MZ Platte Plate	806.4363

Lfd. Nr.	Kennzeichen	Menge	Benennung/Beschreibung	Sachnummer
No.	Unit/Comp.No.	Qty.	Designation	Stock No.
292		1	MZ Platte Plate	806.4357
293		1	ZM Winkel Bracket	804.9822
294		1	ZM Querwand 2 Transverse panel 2	804.9816
295		6	VS M 3x6 DIN 965	081.9378
296		2	WT Führungsleiste f. DS 2E Bl. Guide rail	396.7333
300	A51	1	ED Monitor	805.7317.02
301		1	ZM Kühlwinkel 1 Heat sink bracket 1	805.7769
302		1	ZM Kühlwinkel 2 Heat sink bracket 2	805.7746
303		1	ZM Kühlwinkel 3 Heat sink bracket 3	805.7723
304		3	AZ Montageclip Clip	805.7798
305		10	VS M 3x8 DIN 7985	081.9078
306		10	VS 3 DIN 137	005.0296
307		1	ZM Winkel Bracket	804.9622
308		3	VS M 3x6 DIN 7985	081.9061
310		7	VS M 3x10 DIN 7985	081.9084
311		1	MZ Abdeckung Cover	804.9639
320	A12	1	ED Motherboard	806.0516.02
321		1	MZ Platte Plate	804.9745
322		1	MZ Platte Plate	804.9768
323		3	VS M 3x6 DIN 965	081.9378

Lfd. Nr.	Kennzeichen	Menge	Benennung/Beschreibung	Sachnummer
No.	Unit/Comp.No.	Qty.	Designation	Stock No.
324		4	VS M 3x8 DIN 7985	081.9078
325		4	VS 3 DIN 137	005.0296
326		3	KZ Käfig Insert	085.1936
327		1	MZ Abdeckung Cover	806.0768
330		8	VS 3,2 DIN 125	082.4670
331		11	VS 3 DIN 137	005.0296
332		11	VS M 3x6 DIN 7985	081.9061
335		1	MZ Schiene 3 Rail 3	804.9668
336		11	VS M 3x10 DIN 965	081.9390
337		1	MZ Schiene 5 Rail 5	804.9680
338		1	MZ Schiene 4 Rail 4	804.9674
339		3	VS M 3x6 DIN 965	081.9378
350	A15	1	EE Sub-Motherboard	806.0916.02
351		1	ZM Schiene 1 Rail 1	804.9874
352		1	ZM Schiene 2 Rail 2	804.9897
353		6	VS M 3x10 DIN 965	081.9390
354		2	VS M 3x8 DIN 965	081.9384
360		12	WT Führungsl. f. DS 3E GR. Guide rail	396.7356
361		2	WT Führungsl. f. DS 3E Gb Guide rail	396.7362
362		2	WT Führungsl. f. DS 2E BL Guide rail	396.7333
363		2	WT Führungsl. f. DS 2E RT Guide rail	396.7304
370	A52	1	EE Video Board	805.7817.02